

# Hydraulic 2-Ram-Lift

Type: JAB TwinRam 65.1 S2/2500

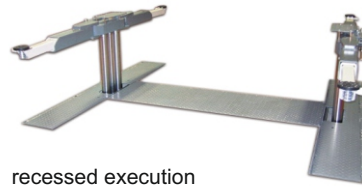

recessed execution

The TwinRam 65.1 S2 is specially designed for lifting of small trucks, vans and SUVs. Available with 2-stage telescopic swing arms it combines all well-known advantages of a swing arm lift like reduced set-up time and best possible accessibility- specially due to the ram distance of 2.500 mm.

With its conception, this lift can be used everywhere in the workshop for reception and repair of vehicles.

## Technical Data

Type	TwinRam 65.1
Lifting capacity	6.500 kg
Ram distance	2.500 mm
Effective stroke	2.190 mm
Lifting time	approx. 45 sec.
Electric motor	4 kW
Oil filling	12 ltr.

## JAB-Advantages

- Foundation cassette and installation frame separately, only screwed together
- Installation frame - hot dip galvanized - mechanically worked on and cross bar with nave connection
- All force is taken up by the installation frame and then led into the ground
- Steel cassette seal welded for installation in water protected area
- Chromium plated piston bars are abrasive-free and totally sealed
- Environmental friendly through low oil quantity and use of biodegradable oils (upon request)
- Hot dip galvanized swing arms for best possible corrosion protection (upon request)
- Many accessories available for all demands
- Easy to maintain through best accessibility
- Highest quality and huge life span
- Advice, after sales and maintenance - all through JAB

*in case you need any further information, don't hesitate to contact us! JAB - Made in Germany*



J.A. Becker & Söhne GmbH & Co KG  
Postfach 1151 · D-74148 Neckarsulm  
Telephone +49 (0) 7132 367-0 · Telefax +49 (0) 7132 367-289  
E-Mail: [info@jab-becker.de](mailto:info@jab-becker.de) / [www.jab-becker.de](http://www.jab-becker.de)



# Detailed dimensions

Type: JAB TwinRam 65.1 S2/2500

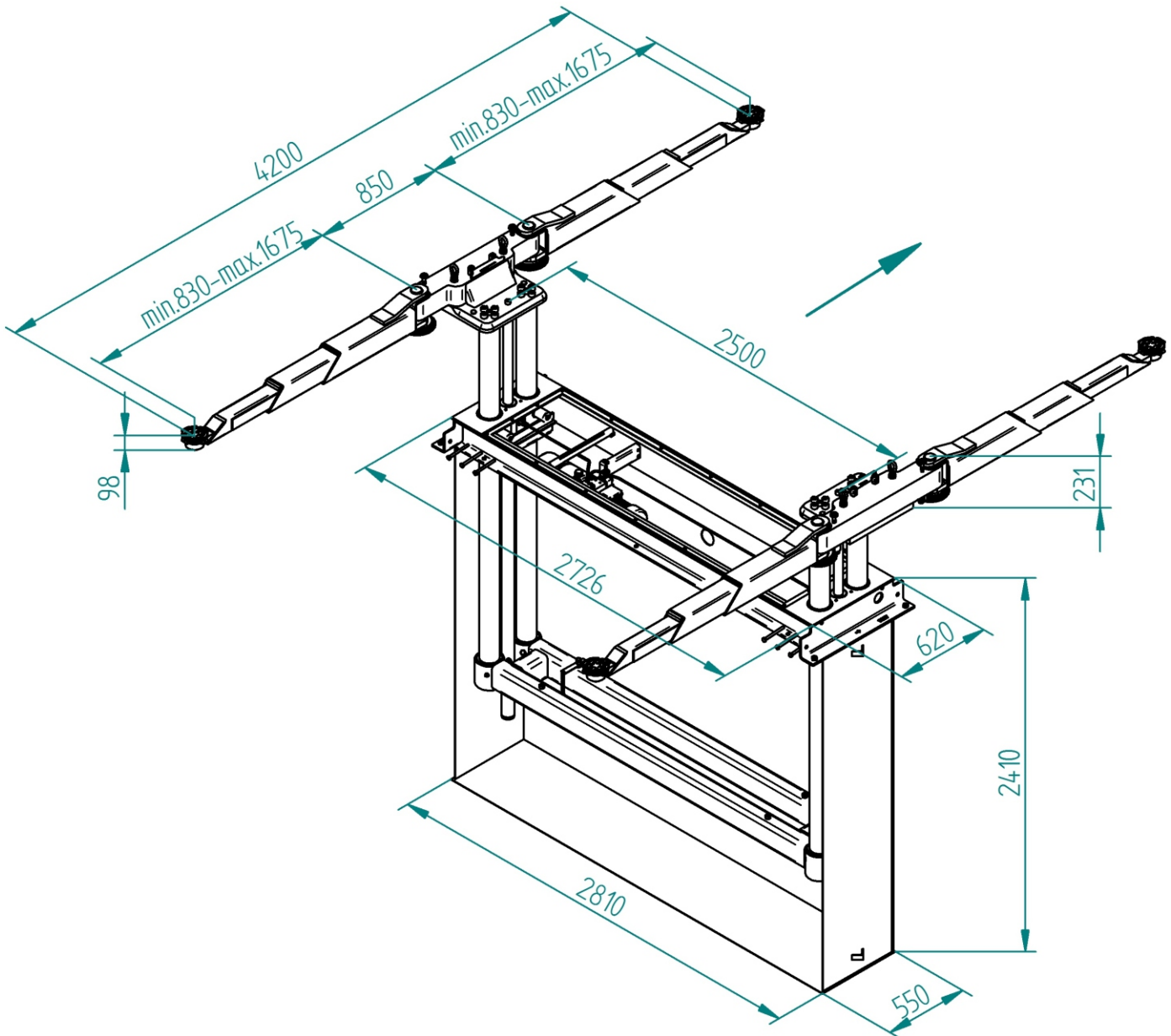

Technical changes and modifications reserved!  
Several executions available!

02/2018



J.A. Becker & Söhne GmbH & Co KG  
Postfach 1151 · D-74148 Neckarsulm  
Telephone +49 (0) 7132 367-0 · Telefax +49 (0) 7132 367-289  
E-Mail: [info@jab-becker.de](mailto:info@jab-becker.de) / [www.jab-becker.de](http://www.jab-becker.de)

