

Hydraulic 2-Ram-Lift

Type: JAB TwinRam 55 S2/1500 & TwinRam 55 S2/2500

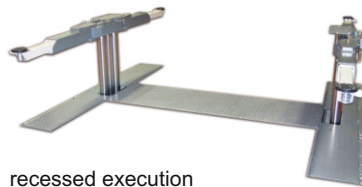

recessed execution

The TwinRam 55 S2 with 2-stage telescopic swing arms combines all well-known advantages of a swing arm lift like reduced set-up time and allows best possible accessibility. It is available with a ram distance of 2.500 as well as 1.500 mm.

With its perfect conception, this lift can be used everywhere in the workshop for reception and repair of passenger cars. Just as well for lifting of small trucks, vans and SUVs.

Technical Data

Type	TwinRam 55 S2/1500	TwinRam 55 S2/2500
Lifting capacity	5.500 kg	5.500 kg
Ram distance	1.500 mm	2.500 mm
Effective stroke	2.000 mm	2.000 mm
Lifting time approx.	45 sec.	45 sec.
Electric motor	2 kW	2 kW
Oil filling	10 ltr.	10 ltr.

JAB-Advantages:

- Foundation cassette and installation frame separately, only screwed together
- Installation frame - hot dip galvanized - mechanically worked on and with cross bar as nave connection
- All forces are taken up by the installation frame and led into the ground
- Foundation cassette seal welded for installation in water protected area
- Chromium plated piston bars are abrasive-free and totally sealed
- Environmental friendly through low oil quantity and use of bio-degradable hydraulic oils (upon request)
- Optional hot dip galvanized swing arms for best possible corrosion protection
- Many accessories available for all demands
- Easy to maintain through best accessibility
- Highest quality and huge life span
- Advice, after sales and maintenance - all through JAB

In case you need any further information, please don't hesitate to contact us! JAB - Made in Germany



J.A. Becker & Söhne GmbH & Co KG
Postfach 1151 · D-74148 Neckarsulm
Telephone +49 (0) 7132 367-0 · Telefax +49 (0) 7132 367-289
E-Mail: info@jab-becker.de / www.jab-becker.de



Detailed dimensions

Type: JAB TwinRam 55 S2/1500 & TwinRam 55 S2/2500

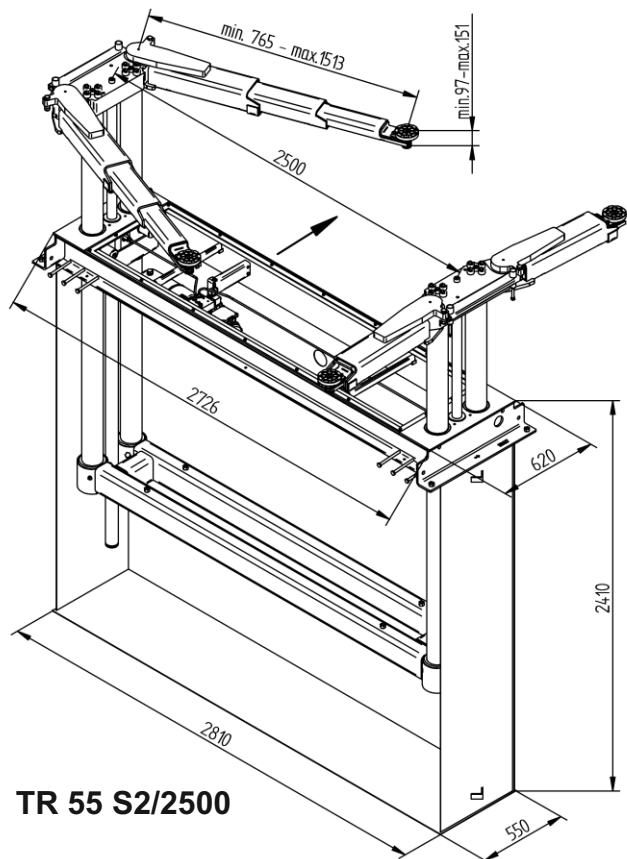
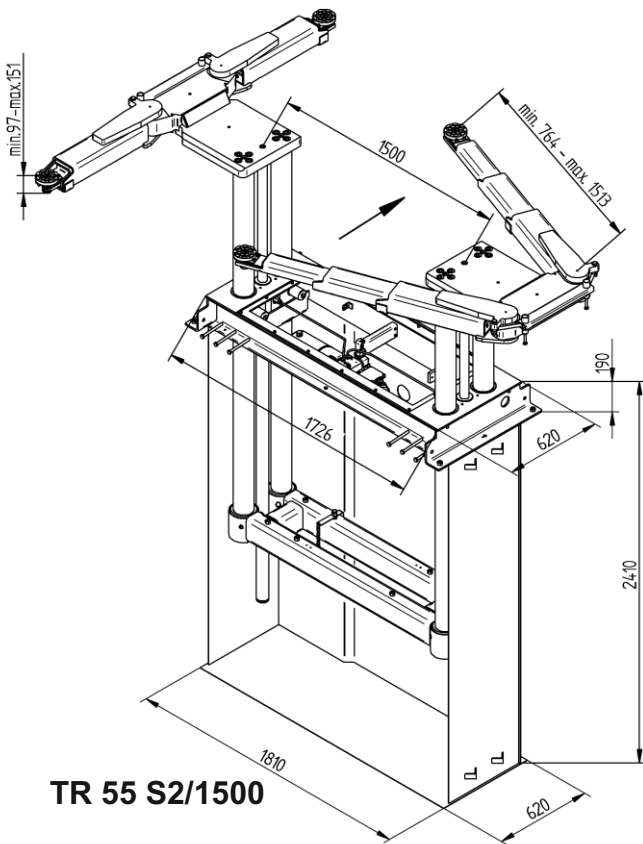

Technical changes and modifications reserved!
Several executions available!

02/2018



J.A. Becker & Söhne GmbH & Co KG
Postfach 1151 · D-74148 Neckarsulm
Telephone +49 (0) 7132 367-0 · Telefax +49 (0) 7132 367-289
E-Mail: info@jab-becker.de / www.jab-becker.de

