

# Hydraulic 2-Ram-Lift

Type: JAB TwinRam 35

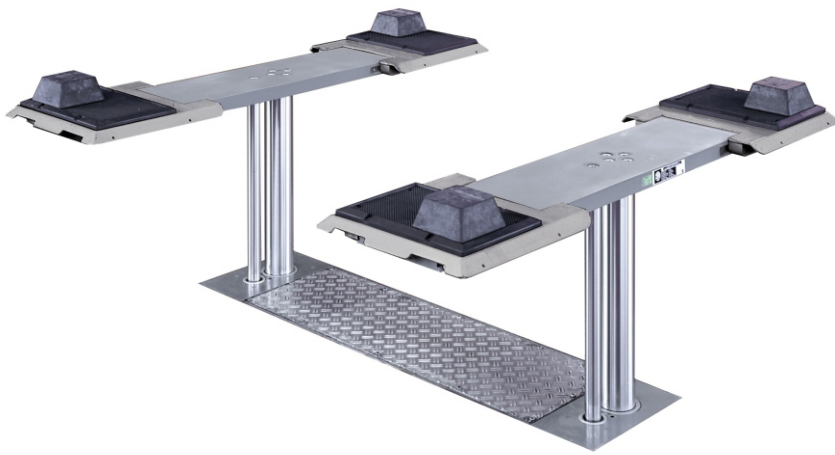

The electro-hydraulic 2-ram lift with pick-up plates (supports lengthwise adjustable) is suitable for fast and safe supporting of vehicles. The pick-up plates are hot dip galvanized in standard execution.

Optional available with pick-up plates UNI with extended lifting range (1.400 - 2.200 mm)!

User-friendly through low drive-over height. The TwinRam 35 simplifies the supporting of vehicles, reduces the set-up time and grants an optimum of accessibility.

This lift is suitable everywhere in the workshop and therefore it is an „allround lift“ with main focus on service reception and repair works. Available with a ram distance of 1.300 mm or 1.700 mm.

## Technical Data

Type	TwinRam35
Lifting capacity	3.500 kg
Ram distance	1.300 mm
Effective stroke	2.042 mm
Lifting time approx.	30 sec.
Electric motor	2 kW
Oil filling	10 ltr.

***In case you need any further information, please don't hesitate to contact us!***

***JAB — Made in Germany***

## JAB-Advantages:

- Foundation cassette and installation frame separately (only screwed together)
- Synchronisation through continuous crossbar
- Chromium plated piston bars are abrasive-free and totally sealed
- All force is taken up by the installation frame and led into the ground
- Foundation cassette seal welded for installation into water protected area
- Very fast lifting of vehicles
- Hydraulic power pack integrated in installation frame, therefore low installation time (no hydraulic hoses)
- Simple reset of different supports
- Environmental friendly through low oil quantity and use of bio-degradable hydraulic oil (upon request)
- Many accessories available for all demands
- Easy to maintain through best accessibility
- Highest quality and huge life span
- Advice, after-sales and maintenance - all through JAB



J.A. Becker & Söhne GmbH & Co KG  
Postfach 1151 · D-74148 Neckarsulm  
Telephone +49 (0) 7132 367-0 · Telefax +49 (0) 7132 367-289  
E-Mail: [info@jab-becker.de](mailto:info@jab-becker.de) / [www.jab-becker.de](http://www.jab-becker.de)



# Detailed dimensions

Type: JAB TwinRam 35

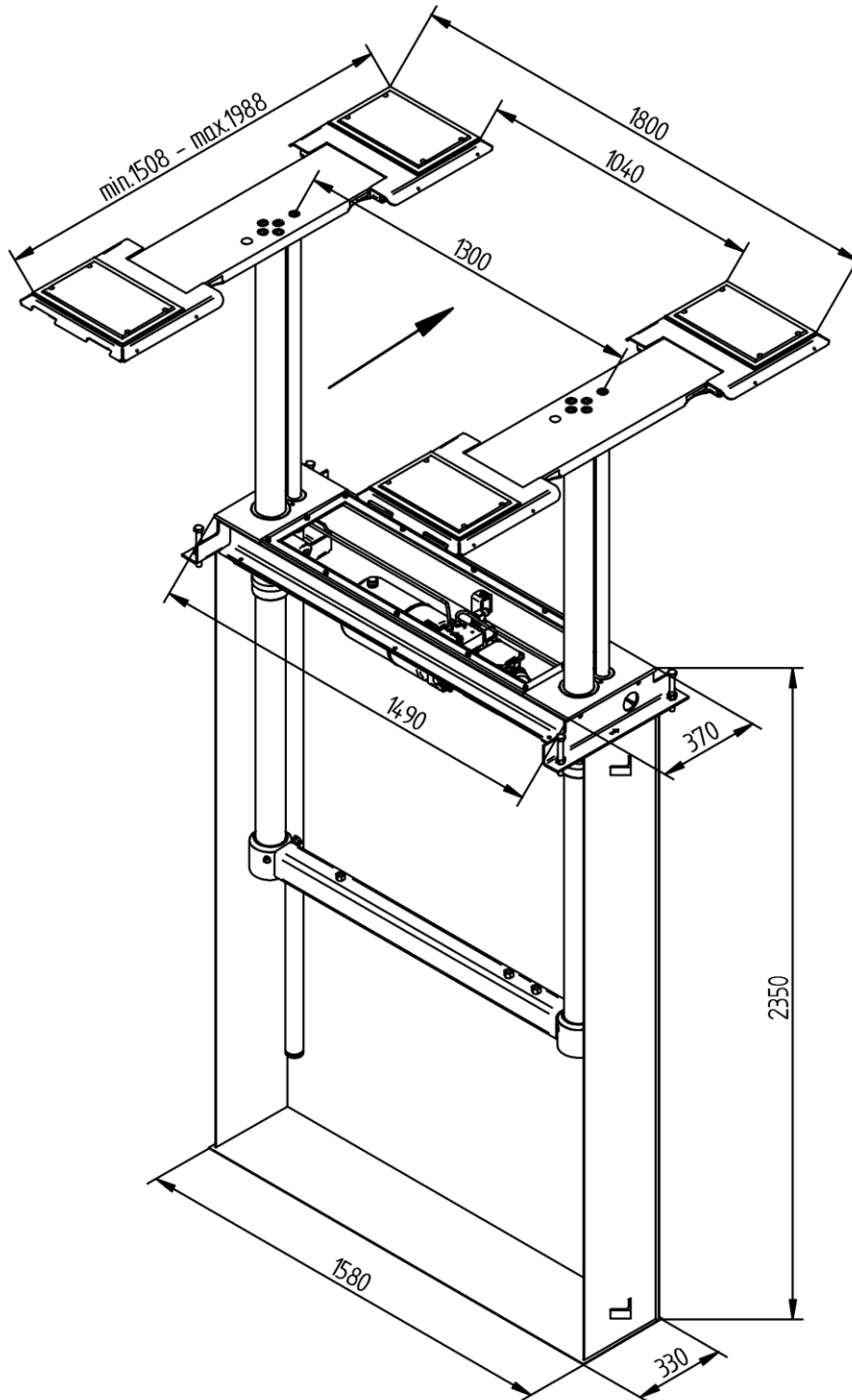

Technical changes and modifications reserved!  
Several executions available!



J.A. Becker & Söhne GmbH & Co KG  
Postfach 1151 · D-74148 Neckarsulm  
Telephone +49 (0) 7132 367-0 · Telefax +49 (0) 7132 367-289  
E-Mail: [info@jab-becker.de](mailto:info@jab-becker.de) / [www.jab-becker.de](http://www.jab-becker.de)



02/2018