

Hydraulic 4-Ram-Lift

Type: JAB QuattroRam 40 A-Align/ QuattroRam 65 A-Align



The hydraulic 4-ram lift QuattroRam A-Align has been developed according to latest requirements of wheel alignment. All parameters of well-known and leading car manufacturers concerning accuracy are achieved fully with this lift. The JAB-QuattroRam is suitable for conventional wheel alignment as well as for touchless sensing technology.

With the QR 40 A-Align the complete passenger car range from smallest to largest wheel base can be handled.

With the QR 65 A-Align we offer a combination with 5 m platform length, which is suitable to lift small truck with long wheel bases as well - combined with the possibility for passenger car wheel alignment.

Due to a mechanical locking in measuring position, the accuracy of the lift is granted by 100 % over many years.

Technical Data

Type	QuattroRam 40 A-Align	QuattroRam 65 A-Align
Lifting capacity	4.000 kg	6.500 kg
Ram distance length/cross:	1.500/2800 mm	1.500/4120 mm
Effective stroke	1.970 mm	1.980 mm
Lifting time approx.	50 sec.	50 sec.
Electric motor	2 x 2 kW	2 x 2 kW
Oil filling	2 x 10 ltr.	2 x 10 ltr.

JAB-Advantages:

- Foundation cassette and installation frame separately (only screwed together)
- All force is taken up by the installation frame and led into the ground
- Extremely low drive-on height of approx. 160 mm
- Spacing for turn tables front 900x500x50 mm* and turn tables /Sliding palets rear 1420 x 500 x 50 mm*
- Platforms undergo heat treatment to relieve stress and are mechanically worked on
- Measuring and calibration position adjustable in lifting steps of 100 mm
- Very fast lifting of vehicle
- Environmental friendly through low oil quantity and use of bio-degradable hydraulic oil (upon request)
- Easy to maintain through best accessibility
- Highest quality and huge life span
- Optional: Illumination and axle lift with 4 tons lifting capacity
- Advice, after-sales and maintenance - all through JAB

In case you need any further information, please don't hesitate to contact us!

JAB — Made in Germany

*Turntables and sliding plates not included in our scope of delivery!



J.A. Becker & Söhne GmbH & Co KG
Postfach 1151 · D-74148 Neckarsulm
Telephone +49 (0) 7132 367-0 · Telefax +49 (0) 7132 367-289
E-Mail: info@jab-becker.de / www.jab-becker.de



Detailed dimensions

Type: JAB QuattroRam 40 A-Align / QuattroRam 65 A-Align

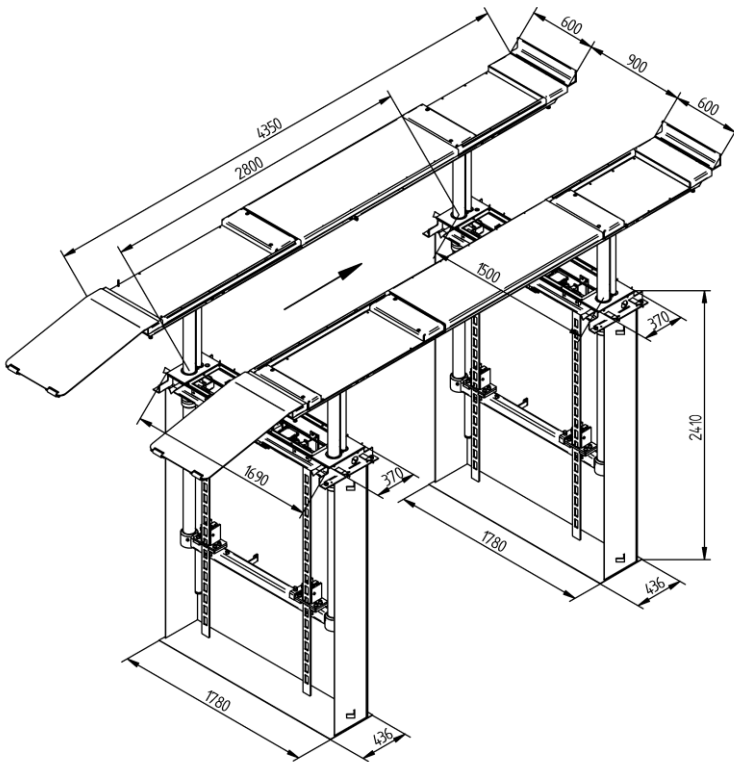

QR 40 A-Align

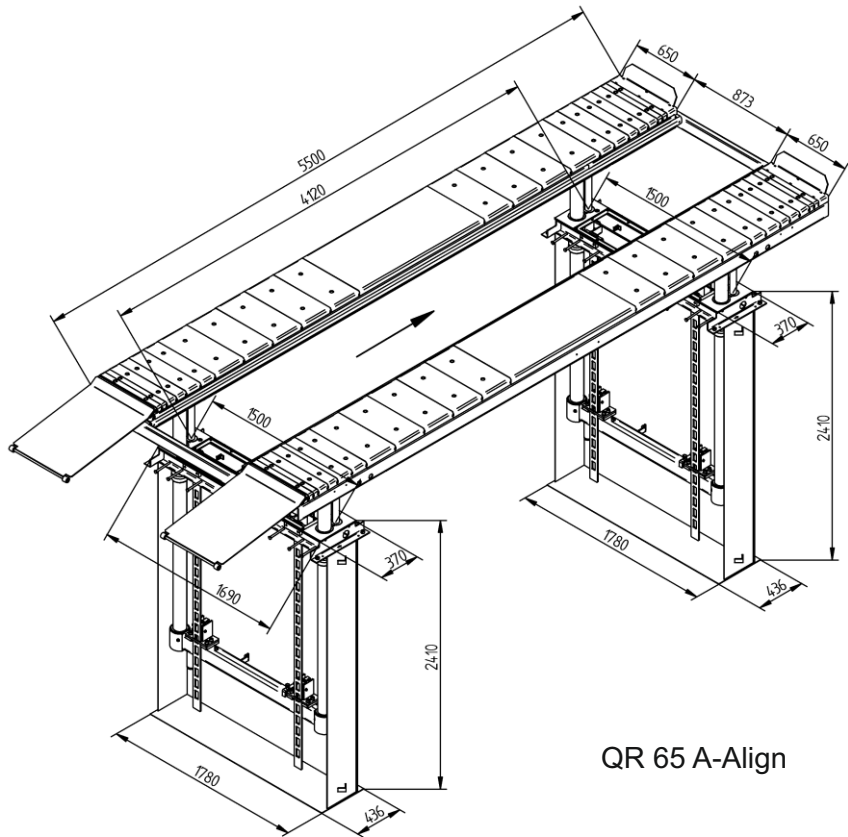

QR 65 A-Align

Technical changes and modifications reserved!
Several executions possible!



J.A. Becker & Söhne GmbH & Co KG
Postfach 1151 · D-74148 Neckarsulm
Telephone +49 (0) 7132 367-0 · Telefax +49 (0) 7132 367-289
E-Mail: info@jab-becker.de / www.jab-becker.de



02/20168